

The **PROJECTOR LIFT VP100** is a versatile product that enables the installation of projectors in environments where particular aesthetical solutions are needed.

The product has been developed to be installed inside false ceilings in order to hide projector, lift and cables, thus granting the best aesthetic and practical solution.

VP100 is supplied with an extremely silent motor that allows a descent from a minimum of 16 cm to a maximum extent of 97 cm.

An interesting element of this lift is a cable gathering system with a raceway where to put the cables of the projector, so they will be hidden and tidy gathered together when the projector lift is moving. The lift is supplied with **safety screws**.

** Ceiling cover plate is NOT included*

Frontal view closed

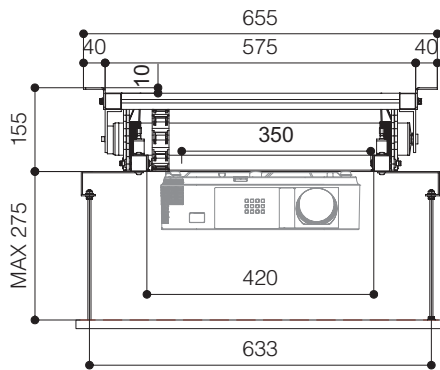

Side view closed

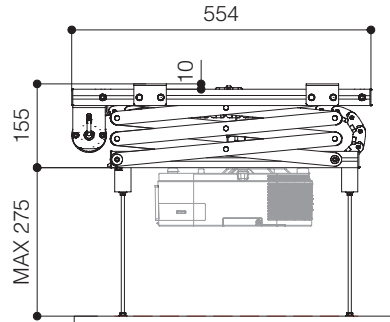

Side view open

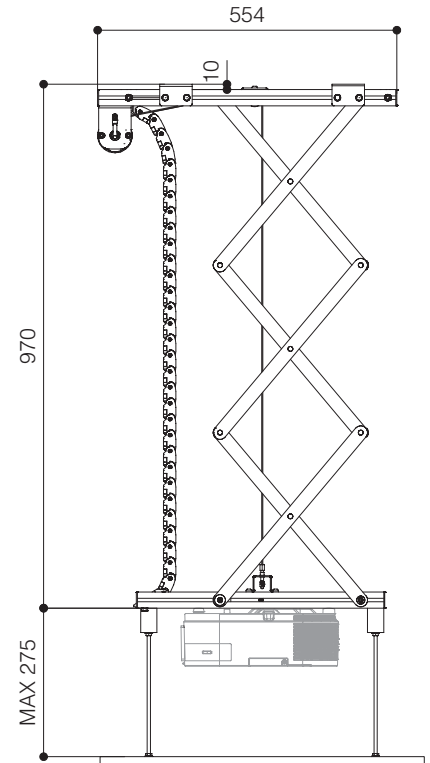

Maximum size projector anchoring points

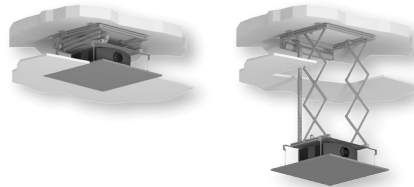
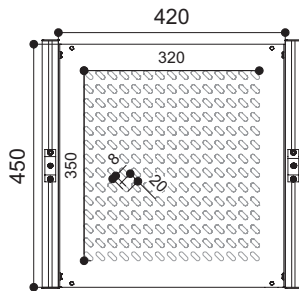

Optionals:

- Ceiling tile holder CT-570
- Kit RF remote control with external receiver
- Interface switch 12 volt
- Low voltage contact interface

TECHNICAL SPECIFICATIONS

POWER SUPPLY	220-230V - 50HZ
MAXIMUM CONSUMPTION	156 W
TORQUE	10 Nm
MOTOR SPEED	17 rpm
DIMENSIONS LIFT CLOSED	575x155x554 (WxHxD in mm)
DIMENSIONS LIFT OPENED	575x970x554 (WxHxD in mm)
MOUNTING PLATE TOTAL DIMENSIONS	420x450 (WxD in mm)
MOUNTING PLATE UPPER INTERNAL DIMENSIONS	350x450 (WxD in mm)
MAXIMUM SIZE FIXING POINTS OF PROJECTOR	320x350 (WxD in mm)
MAXIMUM PROJECTOR DIMENSIONS	560x550 (WxD in mm)
MAXIMUM CAPACITY	15 Kg
NET WEIGHT OF THE PROJECTOR LIFT	12 Kg
CABLE GATHERING SYSTEM (internal dimensions)	20x18 (WxH in mm)

Warranty: 5 years on the motor - 24 months on the other components